



City of the Village of Clarkston
375 Depot Rd
Clarkston, Michigan 48346
City Council Regular Meeting
04 10 2023 Agenda

**NEW: Microsoft Teams meeting Join on your computer @ 7pm,
mobile app or room device [Click here to join the meeting](#)**

Meeting ID: 217 682 328 394 Passcode: 96ueXs

1. Call To Order
2. Pledge Of Allegiance
3. Roll Call
Mayor Haven, Mayor Pro Tem Wylie Council Members: Casey, Forte, Fuller , Lamphier,
Rodgers.
4. Approval Of Agenda - Motion
5. Public Comments:
Individuals have the opportunity to address the City Council on topics not on the
agenda for three minutes. In order to hear all Individuals comments at a
reasonable hour, the City Council request that speakers respect the three-minute
time limit. Note: this is not a question-answer session. However, it is an
opportunity to voice your thoughts with City Council.
6. FYI
Friends of the Clarkston Independence District Library - Spring Book Sale April 25th -
April 29th.

Documents:

[FRIENDS OF THE CLARKSTON INDEPENDENCE DISTRICT LIBRARY.SPRING
SALE.PDF](#)

7. Sheriff Report For March 2023

Documents:

[CITY OF THE VILLAGE MARCH 2023.PDF](#)

8. City Manager Report 04 10 2023

Documents:

[CITY MANAGER REPORT 04.10.2023.PDF](#)

9. Motion: Acceptance Of Consent Agenda As Presented 04 10 2023

Final Minutes: 03 13 2023

Draft Minutes: Draft 03 27 2023

Treasurer's Report: 04 10 2023

Documents:

[04.10.2023 CONSENT AGENDA.PDF](#)

10. Old Business:

a. None

11. New Business:

- a. Resolution: Recommendation from the Friends of Depot Park to name the Depot Park Playground "Optimist Playground".
- b. Resolution: New Depot Road Wayfinding Sign for: Depot Park, Village Hall and Optimist Playground.

Documents:

[RESOLUTION.PLAYGROUND.PDF](#)
[RESOLUTION.CITY HALL SIGNAGE.PDF](#)

12. Resolution: To Enter Into Closed Session

a. Resolution to meet in Closed Session, as permitted by the Open Meetings Act MCL 15.268(e) to discuss the Susan Bisio v City of the Village of Clarkston City Clerk: Karen A. DeLorge, Oakland County Circuit Court CASE NO. 2023-199444-CZ.

b. Motion: Return To Open Session

Documents:

[RESOLUTION_CLOSED SESSION.PDF](#)

13. Adjourn

Only those matters that are on the agenda are to be considered for action.

SCHEDULED MEETINGS - All Regular Council meetings are held in the City Hall unless otherwise noted. For a complete listing of scheduled meetings, please visit the City website: villageofclarkston.org

NOTICE: People with disabilities needing accommodations for effective participation in this meeting should contact the City Clerk (248) 625-1559 at least two working days in advance of the meeting. An attempt will be made to make reasonable accommodations.



FRIENDS
of the
CLARKSTON INDEPENDENCE
DISTRICT LIBRARY



Spring

BOOK SALE

**MEMBERS ONLY
PREVIEW NIGHT**

Tuesday, April 25, 3-7 pm

BOOK SALE



Wednesday, April 26, 10 am-8:30 pm

Thursday, April 27, 10 am-8:30 pm

1/2 PRICE DAY

Friday, April 28, 10 am-5:30 pm

\$5 BAG DAY

Saturday, April 29, 10 am-2 pm



**OAKLAND COUNTY SHERIFF DEPARTMENT
INDEPENDENCE SUBSTATION**

TO: John Smith, City Manager

FROM: Lieutenant Richard Cummins, Substation Commander

SUBJECT: City of the Village of Clarkston Monthly Report

	2023												2023	2022
ARRESTS	JAN	FEB	MAR	APR	MAY	JUN	JUL	AUG	SEP	OCT	NOV	DEC	YTD	YTD
Felony (CLR-059)	0	0	0										0	9
Misdemeanors (CLR-059)	0	1	0										1	86
MICR:														
Violent Crimes (CLR-004)	0	0	0										0	9
Property Crimes (CLR-004)	0	1	0										1	23
TRAFFIC:														
Monthly Citations Citation Report	51	56	77										184	290
Crashes - Crash Report	4	2	3										9	26
LIQUOR INSPECTION ACTIVITY:														
Alcohol Compliance Checks (AE)	0	0	0										0	0
Violations (CLR-065)	0	0	0										0	0
COMMUNITY LIAISON:														
Community Meetings L3535	1	2	2										5	1
Community Other L3539	0	0	0										0	0
STATION STATISTICS:														
Calls for Service (CLR-065)	261	92	118										471	1961

City of the Village of Clarkston
City Manager Report
April 10, 2023

First NoHaz Collection Event April 29th

Starting this year, the City will be once again participating in Oakland County's NoHaz (hazardous waste) collection program. Under the program, City residents will be able drop off acceptable materials for \$15/carload, ensuring that the materials will be disposed of in a safe and environmentally responsible way. In 2023, there will be four collection events: April 29th, June 3rd, July 22nd and September 16th. Visit the County's NoHaz website (www.nohaz.com) to register for the events and for information on the program.

Spring Depot Park Work

Reconstruction of the original Depot Park Rain Garden has been scheduled for May. The redesign will provide a means for minimizing the impact of excess salt washing into the garden from the City Hall driveway. Additionally, the DPW team will soon start bringing in dirt to the main area of the park to provide a better, flatter base for the ice-skating rink. Our plan is to have the dirt graded and grass growing before the first Concert in the Park in June.

Other Upcoming Spring Work

Some other upcoming work projects include:

1. Pothole patching
2. Street sweeping
3. Crosswalk repainting
4. Stump grinding
5. Sidewalk replacement proposal
6. Road repair proposal
7. Removal of tree damaged in winter storm
8. Installation of three EV Charging Stations

Respectfully submitted, **Jonathan Smith, City Manager, April 5, 2023**



City of the Village of Clarkston
Artemus M. Pappas Village Hall
375 Depot Road
Clarkston, Michigan 48346
City Council Regular Meeting Minutes
03 27 2023 **Draft Minutes**

3/27/2023 - Minutes

1. Call To Order

The regular session meeting of the City of the Village of Clarkston City Council was called to order by Mayor Haven at 7:00 P.M.

2. Pledge Of Allegiance

Mayor Haven led the pledge of allegiance.

3. Roll Call

Council Members Present: Eric Haven, Mayor
Laura Rodgers

Council Members: Gary Casey, Mark Lamphier,

Council Members Absent: Sue Wylie, Mayor Pro Tem, Amanda Forte, Bruce Fuller

Others Present: Jonathan Smith, City Manager, Karen A. DeLorge, City Clerk, Tom Ryan, City Attorney,
Sgt. John Ashley

Others Absent: None

4. Approval Of Agenda - Motion

Agenda has been amended by Mayor Haven to remove the following under New Business:

10a. Resolution: Name Depot Park Playground: Optimist Playground.

10b. Resolution: City Hall Signage

Motion as Amended by Haven, supported by Rodgers, to approve the amended agenda as presented - All Aye, Motion Adopted.

MOTION CARRIED 4-0.

5. Public Comments:

Email from Chet Pardee regarding City Revenue and the Finance Committee. Spoke on by Eric Haven, Mayor

6. FYI

Mayor Haven reminded everyone that Spencer Real Estate will be holding their 3rd Annual Egg Hunt on Saturday, April 1, 2023 @ 10 a.m. in Depot Park in Clarkston. For Your Free Tickets Go To:
SpencerSold.com/Events

7. City Manager Report 03 27 2023

Presented by Jonathan Smith, City Manager

The City Manager Report provided the following updates:

- Signage Repairs
- LRIP Grant Funds Received

8. Motion: Acceptance Of Consent Agenda As Presented 03 27 2023

Motioned by Rodgers, supported by Casey to approve the Consent Agenda.

VOTE: All Aye. MOTION CARRIED 4-0

9. Old Business:

9a. Motion: Establishment of a Parking Advisory Committee

Recommendation from the Parking Advisory Committee for a June 1st Launch for Depot Rd Parking Lot.

Motioned by Haven and Seconded by Lamphier for June 1st launch for Depot Rd Parking Lot. VOTE: All Aye.

MOTION CARRIED 4-0.

10. New Business:

a. & b. Removed from agenda by Mayor Haven

c. Request: From Clarkston Arts - to waive the Depot Park rental fee for their August 2nd Harmony in the Park event.

Resolution by Mayor Haven to amend 10c. Request be turned into a Resolution.

Resolved by Haven, supported by Rodgers to approve that 10c. Request be turned into a Resolution.

Roll Call Vote: All Ayes - CASEY, HAVEN, LAMPHIER, RODGERS

RESOLUTION IS ADOPTED 4-0.

Amended 10c. Resolution: The City of the Village of Clarkston hereby waives the Depot Park rental fee for Clarkston Arts August 2nd Harmony in the Park event.

Resolved by Rodgers, supported by Casey to hereby authorizes the City of the Village of Clarkston to waive the Depot Park rental fee for Clarkston Arts August 2nd Harmony in the Park event.

Roll Call Vote: All Ayes - CASEY, HAVEN, LAMPHIER, RODGERS

RESOLUTION IS ADOPTED 4-0.

11. Adjourn

Motion by Rodgers, supported by Casey to adjourn the regular City Council Meeting at 7:21 p.m. - All Aye,
Motion Adopted.

MOTION CARRIED 4-0

Respectfully Submitted by

Karen A. DeLorge, City Clerk.

DRAFT



City of the Village of Clarkston
Artemus M. Pappas Village Hall
375 Depot Road
Clarkston, Michigan 48346
City Council Regular Meeting Minutes
03 13 2023 **Final Minutes**

3/13/2023 - Minutes

1. Call To Order

The regular session meeting of the City of the Village of Clarkston City Council was called to order by Mayor Haven at 7:00 P.M.

2. Pledge Of Allegiance

Mayor Haven led the pledge of allegiance.

3. Roll Call

Council Members Present: Eric Haven, Mayor
Laura Rodgers

Council Members: Gary Casey, Amanda Forte,

Council Members Absent: Sue Wylie, Mayor Pro Tem, Bruce Fuller, Mark Lamphier

Others Present: Jonathan Smith, City Manager, Karen A. DeLorge, City Clerk, Tom Ryan, City Attorney, Sgt. John Ashley

Others Absent: None

4. Approval Of Agenda - Motion

Motioned by Forte, supported by Rodgers, to approve the agenda as presented - All Aye, Motion Adopted.

MOTION CARRIED 4-0.

5. Public Comments:

Email from Chet Pardee regarding city sidewalk repairs. Spoke on by Eric Haven, Mayor

6. FYI

Mayor Haven reminded everyone that CAYA - Clarkston Area Youth Assistance will be holding a kick-off ceremony on Tuesday March 14th @ 8 a.m. at the CCS Board Office.

7. Sheriff Report For February 2023

Presented by Sgt. John Ashley

8. City Manager Report

Presented by Jonathan Smith, City Manager

The City Manager Report provided the following updates:

- No-Haz Program Participation
- DPW Thank You

9. Motion: Acceptance Of Consent Agenda As Presented 03 13 2023

Motioned by Casey. supported by Rodgers to approve the Consent Agenda. VOTE: All Aye.

MOTION CARRIED 4-0

10. Old Business:

10.a. Resolution: 2022 Community Development Block Grant Funding Allocation

Resolved by Rodgers, supported by Casey that the City of the Village of Clarkston hereby allocates it's 2022 CDBG Funding of \$7,000 to the Independence Township Senior Center Transportation Program.

Roll Call Vote: All Ayes - CASEY, FORTE, HAVEN, RODGERS

RESOLUTION IS ADOPTED 4-0.

10.b. Motion: Establishment of a Parking Advisory Committee

The following business owners & homeowners have agreed to be on the committee: Robert Eshaki (Rudy's), Bryan Coudret (2 South Brunch House), Erich Lines (Union Joints & homeowner) and Maggie Sans (homeowner).

Motioned by Rodgers and Seconded by Casey to establish a Parking Advisory Committee.

Roll Call Vote: All Ayes - CASEY, FORTE, HAVEN, RODGERS.

RESOLUTION IS ADOPTED 4-0.

11. New Business:

11.a. Resolution: Depot Park Musical Flower Replacement

Resolved by Rodgers, supported by Casey that the City of the Village of Clarkston hereby authorize the City Manager to purchase a replacement musical flower from Freenotes Harmony Park for \$1,510.95 to be paid from the Park Materials budget (101-265-728.000). The City DPW staff will install the new unit.

Roll Call Vote: All Ayes - CASEY, FORTE, HAVEN, RODGERS

RESOLUTION IS ADOPTED 4-0.

12. Adjourn

Motion by Rodgers, supported by Forte to adjourn the regular City Council Meeting at 7:46 p.m. - All Aye,
Motion Adopted.

MOTION CARRIED 4-0

Respectfully Submitted by

Karen A. DeLorge, City Clerk

TREASURER'S REPORT FOR CITY COUNCIL MEETING:

4/10/2023

Treasurer's Report:

I. Disbursements from 03/01/2023 - 03/31/2023

101 General Fund	\$	92,557.41
202 Major Streets	\$	2,144.32
203 Local Street	\$	781.99
220 Mill Pond Lake	\$	205.40
231 Parking Meter Fund	\$	6,981.22
236 Friends of Depot Park	\$	-
301 GO Bond Debt	\$	1,879.92
401 Capital Projects Fund	\$	1,774.14
590 Sewer Fund	\$	139.56
703 Tax Fund	\$	6,560.51
Total	\$	113,024.47

II. Invoices for review and payment approval

Carlisle Wortman - 2023 Code Enforcement	\$	-
Carlisle Wortman - 2023 Building Administration	\$	-
Carlisle Wortman - Master Plan, Bldg Adm, Planner & Other	\$	-
HRC MS4 Permitting	\$	-
HRC Professional Services Mar 2023	\$	2,651.62
Tom Ryan - Professional Services (Mar Invoice)	\$	1,282.50
Tom Ryan - Professional Services Court (Mar Invoice)	\$	142.50
Total	\$	4,076.62

III. Other Checks for Review

	\$	-
	\$	-
	\$	-
Total	\$	-

GRAND TOTAL	\$	117,101.09
--------------------	-----------	-------------------

CHECK DISBURSEMENT REPORT FOR CITY OF THE VILLAGE OF CLARKSTON
 CHECK DATE FROM 03/01/2023 - 03/31/2023

Check Date	Bank	Check #	Invoice	Payee	Description	Account	Dept	Amount
Fund: 101 GENERAL								
03/01/2023	GEN	10978	8081032	ROYAL PUBLISHING	DUES & CONFERENCES	958.000	101	110.00
03/02/2023	GEN	10979#	0000074003	CHARTER TWP OF INDEPENDENCE	LAW ENFORCEMENT	802.000	301	35,981.64
			0000074003		FIRE PROTECTION - IND TWP	802.001	336	44,126.56
				CHECK GEN 10979 TOTAL FOR FU				80,108.20
03/02/2023	GEN	10980	11059	THOMAS J RYAN PC	LEGAL FEES	803.000	266	1,425.00
			11058		LEGAL FEES	803.000	266	285.00
				CHECK GEN 10980 TOTAL FOR FU				1,710.00
03/02/2023	GEN	10981	0902740758	STATE CHEMICAL SOLUTIONS	DPW SUPPLIES	726.000	441	210.39
03/02/2023	GEN	10982	200429	GREAT LAKES ACE HARDWARE	SUPPLIES-VH BUILDING	726.004	265	122.08
03/06/2023	GEN	10983	200134179932	DTE ENERGY	DTE STREET LIGHTING	926.000	448	1,506.32
03/06/2023	GEN	10984	3/6/2023	DTE ENERGY	DETROIT EDISON-VH	920.000	265	198.34
			3/6/2023		DETROIT EDISON-VH	920.000	265	22.72
			3/6/2023		DETROIT EDISON-VH	920.000	265	4.85
			3/6/2023		DTE UPPER PARKING LOT	923.000	265	171.41
			3/6/2023		DTE UPPER PARKING LOT	923.000	265	15.33
			3/6/2023		DTE UPPER PARKING LOT	923.000	265	15.76
			3/6/2023		DTE DEPOT PARK	923.001	265	28.94
				CHECK GEN 10984 TOTAL FOR FU				457.35
03/06/2023	GEN	10986	335077	VIEW NEWSPAPER GROUP	PUBLICATIONS	901.000	215	323.90
03/07/2023	GEN	10987*#	2/23/2023	CARDMEMBER SERVICE	DUES & CONFERENCES	958.000	101	12.00
			2/23/2023		SUPPLIES	726.000	172	235.14
			2/23/2023		TECHNOLOGY/INTERNET EXPENSE	852.000	172	21.19
			2/23/2023		SUPPLIES	726.000	215	73.68
			2/23/2023		DUES & CONFERENCES	958.000	215	185.00
			2/23/2023		DPW SUPPLIES	726.000	441	29.61
			2/23/2023		DPW EQUIPMENT	726.000	446	366.88
			2/23/2023		MATERIAL & OUTSIDE LABOR-PICKUP TR	861.001	446	1,491.68
			2/23/2023		MATERIAL & OUTSIDE LABOR-DUMP TRUC	861.007	446	307.87
				CHECK GEN 10987 TOTAL FOR FU				2,723.05
03/07/2023	GEN	10988	5066862879	RICOH USA, INC	SUPPLIES	726.000	172	206.87
03/08/2023	GEN	10989	2168292	CARLISLE/WORTMAN ASSOC INC	VH-PLANNER FEES	811.000	701	700.00

04/04/2023 01:34 PM
User: TREASURER2
DB: Clarkston

CHECK DISBURSEMENT REPORT FOR CITY OF THE VILLAGE OF CLARKSTON
CHECK DATE FROM 03/01/2023 - 03/31/2023

Check Date	Bank	Check #	Invoice	Payee	Description	Account	Dept	Amount
Fund: 101 GENERAL								
03/08/2023	GEN	10991	0000074037	CHARTER TOWNSHIP OF INDEPEND	VEHICLES - GAS & OIL	862.000	446	451.76
03/08/2023	GEN	10992	2168380	CARLISLE/WORTMAN ASSOC INC	PROFESSIONAL & CONTRACTUAL SERVICE	805.001	302	370.80
03/08/2023	GEN	10993	2168379	CARLISLE/WORTMAN ASSOCIATES,	BLDG DEPT PROFESSIONAL FEES	809.000	371	1,545.00
03/09/2023	GEN	10994	204389496858	CONSUMERS ENERGY	VH - UTILITIES CONSUMERS	921.000	265	362.36
03/13/2023	GEN	10995	230660051487	BLUE CARE NETWORK	HEALTH INSURANCE	712.000	441	450.46
03/13/2023	GEN	10996	3/13/2023	KAITLYN BALKWELL	MISC EXPENSE	955.000	101	200.00
03/14/2023	GEN	10997	167890425	COMCAST	TELEPHONE	850.000	172	2.22
03/28/2023	GEN	11001	5024344825	RICOH USA INC	RICOH COPIER LEASE	941.000	172	202.65
03/28/2023	GEN	11002	3/301/2023	DOUG WEAVER	PROFESSIONAL & CONTRACTUAL SERVICE	805.001	371	130.00
03/28/2023	GEN	11003	3/31/2023	JEFF SHAFER	SALARY - BLDG INSPECTORS	805.001	371	65.00
03/30/2023	GEN	11004	7763	MICHIGAN MUNICIPAL TREASURER	DUES & CONFERENCES	958.000	101	599.00
Total for fund 101 GENERAL								92,557.41

04/04/2023 01:34 PM
User: TREASURER2
DB: Clarkston

CHECK DISBURSEMENT REPORT FOR CITY OF THE VILLAGE OF CLARKSTON
CHECK DATE FROM 03/01/2023 - 03/31/2023

Check Date	Bank	Check #	Invoice	Payee	Description	Account	Dept	Amount
Fund: 202 MAJOR STREET								
03/01/2023	GEN	10977*	102979	ROAD COMM FOR OAKLAND CTY	SALT - WINTER MAINTENANCE	778.001	453	278.82
03/06/2023	GEN	10985*	103553	ROCK BOTTOM STONE SUPPLY	SALT - WINTER SIDEWALK	778.000	453	304.08
03/08/2023	GEN	10990*	103043	ROAD COMM FOR OAKLAND CTY	SALT - WINTER MAINTENANCE	778.001	453	892.24
03/27/2023	GEN	11000*	103118	ROAD COMM FOR OAKLAND CTY	SALT - WINTER MAINTENANCE	778.001	453	669.18
Total for fund 202 MAJOR STREET								2,144.32

04/04/2023 01:34 PM
User: TREASURER2
DB: Clarkston

CHECK DISBURSEMENT REPORT FOR CITY OF THE VILLAGE OF CLARKSTON
CHECK DATE FROM 03/01/2023 - 03/31/2023

Check Date	Bank	Check #	Invoice	Payee	Description	Account	Dept	Amount
Fund: 203 LOCAL STREET								
03/01/2023	GEN	10977*	102979	ROAD COMM FOR OAKLAND CTY	SALT - WINTER MAINTENANCE	778.001	453	103.13
03/06/2023	GEN	10985*	103553	ROCK BOTTOM STONE SUPPLY	SALT - WINTER SIDEWALK	778.000	453	101.36
03/08/2023	GEN	10990*	103043	ROAD COMM FOR OAKLAND CTY	SALT - WINTER MAINTENANCE	778.001	453	330.00
03/27/2023	GEN	11000*	103118	ROAD COMM FOR OAKLAND CTY	SALT - WINTER MAINTENANCE	778.001	453	247.50
Total for fund 203 LOCAL STREET								781.99

04/04/2023 01:34 PM
User: TREASURER2
DB: Clarkston

CHECK DISBURSEMENT REPORT FOR CITY OF THE VILLAGE OF CLARKSTON
CHECK DATE FROM 03/01/2023 - 03/31/2023

Check Date	Bank	Check #	Invoice	Payee	Description	Account	Dept	Amount
Fund: 220 MILL POND LAKE IMPROVEMENT FUND								
03/06/2023	MILL	268	335075	VIEW NEWSPAPER GROUP	PUBLICATIONS (PUBLIC NOTICES)	902.000	101	205.40
Total for fund 220 MILL POND LAKE IMPROVEMENT								205.40

04/04/2023 01:34 PM
User: TREASURER2
DB: Clarkston

CHECK DISBURSEMENT REPORT FOR CITY OF THE VILLAGE OF CLARKSTON
CHECK DATE FROM 03/01/2023 - 03/31/2023

Check Date	Bank	Check #	Invoice	Payee	Description	Account	Dept	Amount
Fund: 231 PARKING METER FUND								
03/02/2023	PARK	1195	065924	TRAFFIC & SAFETY CONTROL SYS	MISC EXPENSE	955.000	172	5,975.00
03/06/2023	PARK	1196	IRIS0000118441	T2 SYSTEM CANADA INC	MISC EXPENSE	955.000	172	55.00
03/13/2023	PARK	1197	12455	THE PRINT SHOP	MISC EXPENSE	955.000	172	132.50
03/13/2023	PARK	1198	INV-1037084	PASSPORT LABS, INC	MISC EXPENSE	955.000	172	716.51
			INV-1036800		MISC EXPENSE	955.000	172	40.75
				CHECK PARK 1198 TOTAL FOR FU				757.26
03/28/2023	PARK	1199	887103513-253	SPRINT / NEXTEL COMMUNICATIO	PHONE EQUIPMENT	760.000	172	61.46
				Total for fund 231 PARKING METER FUND				6,981.22

04/04/2023 01:34 PM
User: TREASURER2
DB: Clarkston

CHECK DISBURSEMENT REPORT FOR CITY OF THE VILLAGE OF CLARKSTON
CHECK DATE FROM 03/01/2023 - 03/31/2023

Check Date	Bank	Check #	Invoice	Payee	Description	Account	Dept	Amount
Fund: 301 2012 GO BOND DEBT								
03/15/2023	2012	2035	0000000567	CHASE	INTEREST DEBT SERVICE PYMT	993.000	906	1,879.92
Total for fund 301 2012 GO BOND DEBT								1,879.92

04/04/2023 01:34 PM
User: TREASURER2
DB: Clarkston

CHECK DISBURSEMENT REPORT FOR CITY OF THE VILLAGE OF CLARKSTON
CHECK DATE FROM 03/01/2023 - 03/31/2023

Check Date	Bank	Check #	Invoice	Payee	Description	Account	Dept	Amount
Fund: 401 CAPITAL PROJECT FUND								
03/07/2023	GEN	10987*#	2/23/2023	CARDMEMBER SERVICE	FRIENDS OF DEPOT PARK	728.000	265	158.80
			2/23/2023		PROFESSIONAL & CONTRACTUAL SERVICE	805.001	901	125.00
				CHECK GEN 10987 TOTAL FOR FU				<u>283.80</u>
03/14/2023	GEN	10998	DETR 605420	ASI SINAGE INNOVATIONS	STREET SIGNS & POSTS	819.000	446	1,137.96
03/20/2023	GEN	10999	403243352	ADT	PROFESSIONAL & CONTRACTUAL SERVICE	805.001	901	352.38
					Total for fund 401 CAPITAL PROJECT FUND			1,774.14

04/04/2023 01:34 PM
User: TREASURER2
DB: Clarkston

CHECK DISBURSEMENT REPORT FOR CITY OF THE VILLAGE OF CLARKSTON
CHECK DATE FROM 03/01/2023 - 03/31/2023

Check Date	Bank	Check #	Invoice	Payee	Description	Account	Dept	Amount
Fund: 590 SEWER								
03/20/2023	SEWER	2117	300-2112-S	GREAT LAKES WATER AUTHORITY	IWC CHARGES IND TWP	814.002	536	139.56
Total for fund 590 SEWER								139.56

04/04/2023 01:34 PM
 User: TREASURER2
 DB: Clarkston

CHECK DISBURSEMENT REPORT FOR CITY OF THE VILLAGE OF CLARKSTON
 CHECK DATE FROM 03/01/2023 - 03/31/2023

Check Date	Bank	Check #	Invoice	Payee	Description	Account	Dept	Amount
Fund: 703 TAX								
03/09/2023	TAX	2843	3/8/2023	NICHOLAS VANDEBERG	TAX COLLECTIONS	274.000	000	100.08
03/09/2023	TAX	834 (E)	3/8/2023	CLARKSTON COMMUNITY SCHOOLS	TAX COLLECTIONS	274.000	000	604.72
03/09/2023	TAX	835 (E)	3/8/2023	OAKLAND COUNTY TREASURER	TAX COLLECTIONS	274.000	000	2,105.91
03/09/2023	TAX	836 (E)	3/8/2023	CITY OF CLARKSTON CVT	TAX COLLECTIONS	274.000	000	2,445.81
03/09/2023	TAX	837 (E)	3/8/2023	CITY OF CLARKSTON 2012 BOND	TAX COLLECTIONS	274.000	000	316.11
03/09/2023	TAX	838 (E)	3/8/2023	CLARKSTON INDEPENDENCE DISTR	TAX COLLECTIONS	274.000	000	356.68
03/09/2023	TAX	839 (E)	3/8/2023	CITY OF CLARSTKON SEWER-DELQ	TAX COLLECTIONS	274.000	000	631.20
						Total for fund 703 TAX		6,560.51
TOTAL - ALL FUNDS								113,024.47

'*'-INDICATES CHECK DISTRIBUTED TO MORE THAN ONE FUND
 '#'-INDICATES CHECK DISTRIBUTED TO MORE THAN ONE DEPARTMENT



HUBBELL, ROTH & CLARK, INC.
 CONSULTING ENGINEERS
 PO BOX 824
 BLOOMFIELD HILLS, MICHIGAN 48303-0824
 (248) 454-6300

March 17, 2023
 Project No: 20220887.02
 Invoice No: 0204702

CITY OF THE VILLAGE OF CLARKSTON
 375 DEPOT ROAD
 CLARKSTON, MI 48346

ATTN: JONATHAN SMITH, CITY MANAGER

DOWNTOWN SIDEWALK REVIEW
 STUDY PLAN REVIEW

Professional Services for period ending February 4, 2023

Professional Personnel

	Hours	Amount	
Totals	1.50	114.62	
Total Labor	2.0 times	114.62	229.24
Total Due this Invoice			<u>\$229.24</u>

JS

Billings to Date

	Current	Prior	Total
Labor	229.24	1,412.10	1,641.34
Totals	229.24	1,412.10	1,641.34

101-701-810.001

Billing Backup

HUBBELL, ROTH & CLARK, INC.

Invoice 0204702 Dated 3/17/2023

Friday, March 17, 2023

11:40:00 AM

Professional Personnel

			Hours		Amount	
01769	SLICKER, MATTHEW	1/21/2023	.50	76.41	38.21	
01769	SLICKER, MATTHEW	1/21/2023	1.00	76.41	76.41	
	Totals		1.50		114.62	
	Total Labor			2.0 times	114.62	229.24

Total this Project \$229.24

Total this Report \$229.24



HUBBELL, ROTH & CLARK, INC.
 CONSULTING ENGINEERS
 PO BOX 824
 BLOOMFIELD HILLS, MICHIGAN 48303-0824
 (248) 454-6300

March 17, 2023
 Project No: 20220888.02
 Invoice No: 0204705

CITY OF THE VILLAGE OF CLARKSTON
 375 DEPOT ROAD
 CLARKSTON, MI 48346

ATTN: JONATHAN SMITH, CITY MANAGER

MILL POND OUTLET REVIEW
 STUDY PLAN REVIEW

Professional Services for period ending February 4, 2023

Professional Personnel

	Hours	Amount	
Totals	2.00	134.81	
Total Labor		134.81	269.62
	2.0 times		
Total Due this Invoice			<u>\$269.62</u>

JS

Billings to Date

	Current	Prior	Total
Labor	269.62	382.06	651.68
Totals	269.62	382.06	651.68

101-701-810.001

Billing Backup

HUBBELL, ROTH & CLARK, INC.

Invoice 0204705 Dated 3/17/2023

Friday, March 17, 2023

11:48:48 AM

Professional Personnel

			Hours		Amount	
02017	FORTINO, NICOLE	2/4/2023	.50	40.37	20.19	
01769	SLICKER, MATTHEW	2/4/2023	1.00	76.41	76.41	
01769	SLICKER, MATTHEW	2/4/2023	.50	76.41	38.21	
	Totals		2.00		134.81	
	Total Labor			2.0 times	134.81	269.62

Total this Project \$269.62

Total this Report \$269.62



HUBBELL, ROTH & CLARK, INC.
 CONSULTING ENGINEERS
 PO BOX 824
 BLOOMFIELD HILLS, MICHIGAN 48303-0824
 (248) 454-6300

March 17, 2023
 Project No: 20220889.02
 Invoice No: 0204707

CITY OF THE VILLAGE OF CLARKSTON
 375 DEPOT ROAD
 CLARKSTON, MI 48346

ATTN: JONATHAN SMITH, CITY MANAGER

DEPOT PARK NATURE TRAIL
 STUDY PLAN REVIEW

Professional Services for period ending February 4, 2023

Professional Personnel

	Hours	Amount	
Totals	4.50	337.05	
Total Labor		337.05	674.10
	2.0 times		
Total Due this Invoice			<u>\$674.10</u>

JS

Billings to Date

	Current	Prior	Total
Labor	674.10	3,566.74	4,240.84
Totals	674.10	3,566.74	4,240.84

101-701-810.001

Billing Backup

HUBBELL, ROTH & CLARK, INC.

Invoice 0204707 Dated 3/17/2023

Friday, March 17, 2023

12:02:22 PM

Professional Personnel

			Hours		Amount	
01747	STRATELAK, DEREK	1/21/2023	4.50	74.90	337.05	
	Totals		4.50		337.05	
	Total Labor			2.0 times	337.05	674.10
					Total this Project	\$674.10
					Total this Report	\$674.10



HUBBELL, ROTH & CLARK, INC.
 CONSULTING ENGINEERS
 PO BOX 824
 BLOOMFIELD HILLS, MICHIGAN 48303-0824
 (248) 454-6300

March 17, 2023
 Project No: 20230086.22
 Invoice No: 0204708

CITY OF THE VILLAGE OF CLARKSTON
 375 DEPOT ROAD
 CLARKSTON, MI 48346

ATTENTION: JONATHON SMITH, CITY MANAGER

12 SOUTH MAIN ST
 SEWER VIDEO REVIEW

Professional Services for period ending February 4, 2023

Professional Personnel

	Hours	Amount	
Totals	1.00	53.36	
Total Labor		53.36	106.72
	2.0 times		
Total Due this Invoice			<u>\$106.72</u>

JS

Billings to Date

	Current	Prior	Total
Labor	106.72	0.00	106.72
Totals	106.72	0.00	106.72

101-701-810.001

Billing Backup

HUBBELL, ROTH & CLARK, INC.

Invoice 0204708 Dated 3/17/2023

Friday, March 17, 2023

12:04:48 PM

Professional Personnel

			Hours	Amount		
02312	HUGHES, MATTHEW	2/4/2023	1.00	53.36	53.36	
	Totals		1.00		53.36	
	Total Labor			2.0 times	53.36	106.72
					Total this Project	\$106.72
					Total this Report	\$106.72



HUBBELL, ROTH & CLARK, INC.
 CONSULTING ENGINEERS
 PO BOX 824
 BLOOMFIELD HILLS, MICHIGAN 48303-0824
 (248) 454-6300

March 17, 2023
 Project No: 20200436.03
 Invoice No: 0204700

CITY OF THE VILLAGE OF CLARKSTON
 375 DEPOT ROAD
 CLARKSTON, MI 48346

ATTENTION: JONATHON SMITH, CITY MANAGER

12 SOUTH MAIN STREET ALLEY STORM AND SANITARY SEWER
 TOPOGRAPHIC SURVEY

Professional Services for period ending February 4, 2023

Professional Personnel

	Hours	Amount	
Totals	6.50	379.53	
Total Labor		379.53	759.06
			2.0 times
			Total Due this Invoice
			\$759.06

JS

Billings to Date

	Current	Prior	Total
Labor	759.06	1,045.12	1,804.18
Totals	759.06	1,045.12	1,804.18

101-701-810.001

Billing Backup

Friday, March 17, 2023

HUBBELL, ROTH & CLARK, INC.

Invoice 0204700 Dated 3/17/2023

11:33:30 AM

Professional Personnel

			Hours	Amount		
02316	JACOBI, STEPHEN	2/4/2023	.50	76.02	38.01	
02317	ROZEMA, MARK	2/4/2023	6.00	56.92	341.52	
	Totals		6.50		379.53	
	Total Labor			2.0 times	379.53	759.06

Total this Project \$759.06

Total this Report \$759.06



HUBBELL, ROTH & CLARK, INC.
 CONSULTING ENGINEERS
 PO BOX 824
 BLOOMFIELD HILLS, MICHIGAN 48303-0824
 (248) 454-6300

March 17, 2023
 Project No: 20200436.06
 Invoice No: 0204701

CITY OF THE VILLAGE OF CLARKSTON
 375 DEPOT ROAD
 CLARKSTON, MI 48346

ATTENTION: JONATHON SMITH, CITY MANAGER

12 SOUTH MAIN STREET ALLEY STORM AND SANITARY SEWER
 OBSERVATION

Professional Services for period ending February 4, 2023

Professional Personnel

	Hours	Amount	
Totals	4.50	306.44	
Total Labor		306.44	612.88
	2.0 times		
			612.88
			\$612.88
			<i>JS</i>

Total Due this Invoice

Billings to Date

	Current	Prior	Total
Labor	612.88	0.00	612.88
Totals	612.88	0.00	612.88

101-701-810.001

Billing Backup

HUBBELL, ROTH & CLARK, INC.

Invoice 0204701 Dated 3/17/2023

Friday, March 17, 2023

11:37:19 AM

Professional Personnel

			Hours		Amount	
01535	DEFRAIN, ROBERT	1/21/2023	1.50	85.05	127.58	
01339	PENNYCOOK, WILLIAM	1/21/2023	3.00	59.62	178.86	
	Totals		4.50		306.44	
	Total Labor			2.0 times	306.44	612.88

Total this Project \$612.88

Total this Report \$612.88

Thomas J. Ryan, P.C.

2055 Orchard Lake Road
Sylvan Lake, MI 48320

Invoice submitted to:
Jonathan Smith
City Manager
City of the Village of Clarkston
375 Depot Road
Clarkston, MI 48346

April 4, 2023

Invoice #11062

Professional Services

	<u>Hrs/Rate</u>	<u>Amount</u>	
3/2/2023 Review Lehman's Reply Brief; Email a copy to City Manager and HDC Chair re: 42 W. Washington	1.00 95.00/hr	95.00	✓
3/6/2023 Phone call to City manager re: miscellaneous city matters	0.50 95.00/hr	47.50	✓
Phone call from HDC Chair Meloche re: 9 Miller Road	0.50 95.00/hr	47.50	✓
Review email from Ms. Forte re: 42 W. Washington; Email to Ms. Forte re: 42 W. Washington; copy to City Manager and Council	0.50 95.00/hr	NO CHARGE	✓
3/10/2023 Review packet of emails regarding Millpond and Mrs. Bisio's FOIA request (emails/documents not received by City Attorney as correspondence was copied to old AOL email address)	2.00 95.00/hr	190.00	✓
3/13/2023 Review Council Meeting packet for 3/13/23 Council Meeting	0.50 95.00/hr	47.50	✓
Attend City Council Meeting	2.00 95.00/hr	190.00	✓
3/27/2023 Review Council packet for 3/27/23 council meeting	0.50 95.00/hr	47.50	✓
Phone call from HDC Chair Meloche re: 9 Miller Road issues	0.50 95.00/hr	47.50	✓
Attend City Council Meeting; discussions with City Manager and Mayor	2.00 95.00/hr	190.00	✓
3/30/2023 Review draft Minutes of HDC meeting of 3/14/23 and draft Notice of Denial Re: 9 Miller Road; Phone call to HDC Chair Meloche	1.00 95.00/hr	95.00	✓

	<u>Hrs/Rate</u>	<u>Amount</u>
3/30/2023 Review correspondence from City Clerk re: attached Summons and Complaint re: Susan Bisio FOIA lawsuit; Phone calls to City Manager, City Clerk, Michigan Municipal League re: new lawsuit	1.50 95.00/hr	142.50 ✓
3/31/2023 Review email correspondence from Mr. Bisio re: Evidence Preservation Letter re: Susan Bisio FOIA lawsuit; Phone call to Mayor Haven re: Letter; Phone call to City Manager re: Letter; Phone call with Michigan Municipal League re: notice of claim	1.50 95.00/hr	142.50 ✓
For professional services rendered	<u>14.00</u>	<u>\$1,282.50</u> JS
Previous balance		\$1,425.00
Accounts receivable transactions		
3/14/2023 Payment - Thank You (Check No. 10980)		(\$1,425.00)
Total payments and adjustments		<u>(\$1,425.00)</u>
Balance due		<u><u>\$1,282.50</u></u>

Thomas J. Ryan, P.C.

2055 Orchard Lake Road
Sylvan Lake, MI 48320

Invoice submitted to:
Jonathan Smith
City Manager
375 Depot Road
Clarkston, MI 48346

April 4, 2023

In Reference To: Clarkston Court/Prosecution
Invoice #11063

Professional Services

	<u>Hrs/Rate</u>	<u>Amount</u>
3/27/2023 Review Notice to Appear from 52/2 District Court re: court hearing on 5/3/23 before Judge Kostin - Case No. 23-000753	0.50 95.00/hr	47.50
3/28/2023 Review Police Report No. 22OS31112; Email police report to attorney for Defendant, Mr. Vitale	1.00 95.00/hr	95.00
For professional services rendered	1.50	\$142.50
Previous balance		\$285.00
Accounts receivable transactions		
3/14/2023 Payment - Thank You No. 10980		(\$285.00)
Total payments and adjustments		(\$285.00)
Balance due		<u><u>\$142.50</u></u>

City of the Village of Clarkston

375 Depot Road
Clarkston, Michigan 48346

Resolution - Depot Park Playground

Whereas, Depot Park is a central and valued asset to the City of The Village of Clarkston; "A place of recreation, education, inspiration, commemoration and repose", and;

WHEREAS, hundreds of local children, from within the village limits and surrounding region, come to play in the Depot Park playground every year, and;

WHEREAS, The Friends of Depot Park, committee of city council, are continually looking for corporate and civic partners to sponsor the addition of quality assets to the playground and park at large, and;

WHEREAS, the Optimist Club of Clarkston, Michigan has been the largest contributor, by far, (\$70,000) of funds to supply children-valued equipment (see pictures) to the playground of Depot, Park. The list is extensive: a merry-goround (2007), a skating rink (2012), tot swing, "Geo Climber", and mulch (2017), tire swing, "Cozy Coocon" (2018), xylophone (2019), slide, rock climbing structure, (2019), an updated skating rink (2020) and kids bridge (2022), and;

WHEREAS, the Optimist Club has donated much labor and know-how for installation of this equipment, and;

WHEREAS, the contributions of labor and leadership from Optimist Club members on the Friends of Depot Park (committee of city council) has been present since the inception of the Friends of Depot Park Committee, in 2017, and;

WHEREAS, the playground in Depot Park has never before had a name or caring contributor like the Optimist Club, and;

WHEREAS, it is acknowledged by the Optimist Club and the Friends of Depot Park that our mutual benefits and long term relationship will be enhanced by recognizing the contributions of the Optimist Club by naming the playground, "Optimist Playground", and;

NOW THEREFORE, let it be resolved that the playground in Depot Park will henceforth be named "Optimist Playground".

Casey	Forte	Fuller	Haven	Lamphier	Rodgers	Wylie	Totals
<input type="checkbox"/> Yes	<input type="checkbox"/> Yes	<input type="checkbox"/> Yes	<input type="checkbox"/> Yes	<input type="checkbox"/> Yes	<input type="checkbox"/> Yes	<input type="checkbox"/> Yes	<input type="checkbox"/> Yes
<input type="checkbox"/> No	<input type="checkbox"/> No	<input type="checkbox"/> No	<input type="checkbox"/> No	<input type="checkbox"/> No	<input type="checkbox"/> No	<input type="checkbox"/> No	<input type="checkbox"/> No
<input type="checkbox"/> Abstain	<input type="checkbox"/> Abstain	<input type="checkbox"/> Abstain	<input type="checkbox"/> Abstain	<input type="checkbox"/> Abstain	<input type="checkbox"/> Abstain	<input type="checkbox"/> Abstain	<input type="checkbox"/> Abstain
<input type="checkbox"/> Absent	<input type="checkbox"/> Absent	<input type="checkbox"/> Absent	<input type="checkbox"/> Absent	<input type="checkbox"/> Absent	<input type="checkbox"/> Absent	<input type="checkbox"/> Absent	<input type="checkbox"/> Absent

Resolution is Adopted

Resolution is Defeated

Karen DeLorge, City Clerk

April 10, 2023

Date

City of the Village of Clarkston

375 Depot Road
Clarkston, Michigan 48346

Resolution - City Hall Signage

WHEREAS, the City purchased and installed new street and wayfinding signage in 2020, and;

WHEREAS, a wayfinding sign at the corner of Main Street and Depot Road (photo attached) directs pedestrians and drivers down Depot Road to reach Depot Park and the Village Hall, but subsequent signage on Depot Road was not included in the sign project, and;

WHEREAS, a common complaint received in the City Office from delivery drivers and other visitors is that they could not find the office, even when using GPS-based mapping tools, and;

WHEREAS, to address this complaint, the sign shown in the attached mock-up is proposed for the intersection of Depot Road and the City Hall driveway, and;

WHEREAS, ASI Signage, the manufacturer of the City signs, has prepared that attached quote for \$2,380 to fabricate the proposed sign, and;

NOW THEREFORE, BE IT RESOLVED that the City of the Village of Clarkston hereby authorizes the City Manager to purchase and install the proposed wayfinding sign for \$2,380, to be funded by the Professional & Contractual Services budget (401-901-805.001).

Casey	Forte	Fuller	Haven	Lamphier	Rodgers	Wylie	Totals
<input type="checkbox"/> Yes	<input type="checkbox"/> Yes	<input type="checkbox"/> Yes	<input type="checkbox"/> Yes	<input type="checkbox"/> Yes	<input type="checkbox"/> Yes	<input type="checkbox"/> Yes	<input type="checkbox"/> Yes
<input type="checkbox"/> No	<input type="checkbox"/> No	<input type="checkbox"/> No	<input type="checkbox"/> No	<input type="checkbox"/> No	<input type="checkbox"/> No	<input type="checkbox"/> No	<input type="checkbox"/> No
<input type="checkbox"/> Abstain	<input type="checkbox"/> Abstain	<input type="checkbox"/> Abstain	<input type="checkbox"/> Abstain	<input type="checkbox"/> Abstain	<input type="checkbox"/> Abstain	<input type="checkbox"/> Abstain	<input type="checkbox"/> Abstain
<input type="checkbox"/> Absent	<input type="checkbox"/> Absent	<input type="checkbox"/> Absent	<input type="checkbox"/> Absent	<input type="checkbox"/> Absent	<input type="checkbox"/> Absent	<input type="checkbox"/> Absent	<input type="checkbox"/> Absent

Resolution is Adopted

Resolution is Defeated

Karen DeLorge, City Clerk

April 10, 2023

Date

Order No. DETR 205639

March 24, 2023
Page 1 of 1



Customer City of the Village of Clarkston
Location Primary Location
Reference DIR Directional Sign

Bill to
City of the Village of Clarkston
Mr. Jonathan Smith
375 Depot
Clarkston, MI 48346
US
T: (248) 625-1559
M: (248) 909-3380
Email: smithj@villageofclarkston.org

Ship to
City of the Village of Clarkston
Mr. Jonathan Smith
375 Depot
Clarkston, MI 48346
US
T: (248) 625-1559
M: (248) 909-3380
Email: smithj@villageofclarkston.org

Quote Ref. DETR-405573	Due Date 04/21/2023	Service Date	SR Craig Breeden
F.O.B. Shipping Point	Client PO Email Jonathan	Ship Date 04/21/2023	PM Amy Davenport
Terms 1/2 Deposit balance Net 30		Ship Method Customer Pickup	

No.	Item	Description	Qty	UOM	Unit Price	Extension
1.	DIR	Sign Type DIR, to read: Side A < Village Hall < Depot Park < Optimists Playground Side B > Village Hall > Depot Park > Optimists Playground	1	Each	2,380.00	2,380.00

Subtotal	2,380.00
Sales Tax (0 %)	0.00
Total	2,380.00
Less Deposit	0.00
Uninvoiced Amt	2,380.00

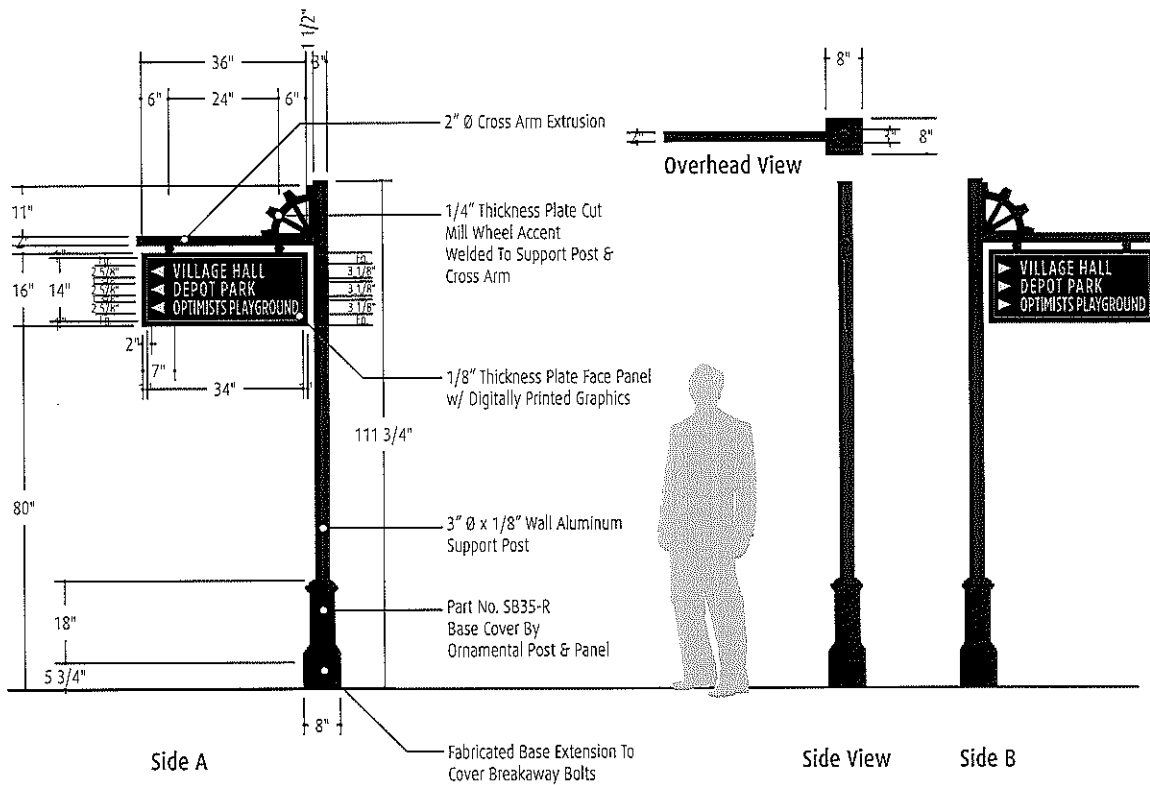

Actual Copy: (As Illustrated)

FWO No.: 205639 Date: 3/24/23

Client: City of the Village of Clarkston

Project: Clarkston, MI

Sign Type: **DIR-1**

Description: General Directional

Product Code: ALM (Custom)
Size: 16"x36" Face

Quantity: 1 (Double Faced)

Graphics Process: Digital Print On Panel

Typography: 14"x34" (~1/8" Thickness) Border Typ.
2-5/8" Custom Arrows
3-1/8" Gotham Condensed Medium, U/C (Kearned/Condense To Fit As Needed)

Graphics Color: PMS 9161C Beige

Frames & Fixtures: Provided (1) 3" Ø Post w/ 2" Ø Cross Rail & Custom Mill Wheel Detail, To Include SB35-R Base Cover w/ Extended Bolt Cover Per Attached Details, Painted SC-905 Black.

Background Color: SC-905 Black
Semi Gloss Clearcoat (SOA365SP/01) After Printing

Installation Method: Suspended Mount From Cross Rail Per Attached Construction Details

Production Notes:

Submittal Comments

Please Check One:

- Approved As Submitted
- Approved As Noted
- Revise And Resubmit

Reviewed By:

Date:

Additional Notes:

This drawing is the property of ASI. This drawing is submitted under a confidential relationship for a specified purpose and the recipient, by accepting this document, assumes custody and agrees that this document will not be copied or reproduced in whole or in part, nor its contents revealed in any manner or to any person except to meet the purpose for which it was delivered without express written permission.



1119 Wheaton
Troy, MI 48063
ph 248.680.8970
fx 248.680.9061

Drawings Shown In Proportion But Not To Scale

Please Fax Or Mail Drawings To The Address At Left

Dwg: AD Page of Proofed:

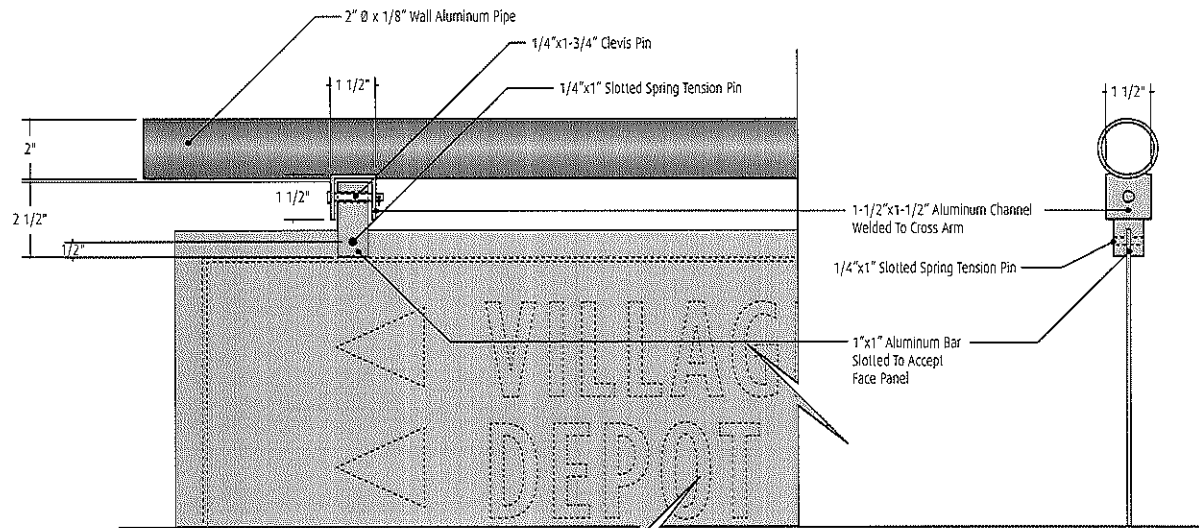

Panel/Hinge Detail

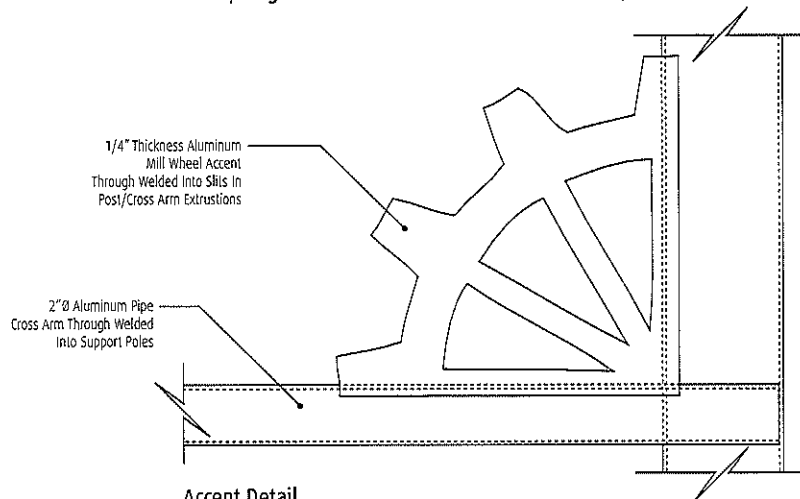

Accent Detail

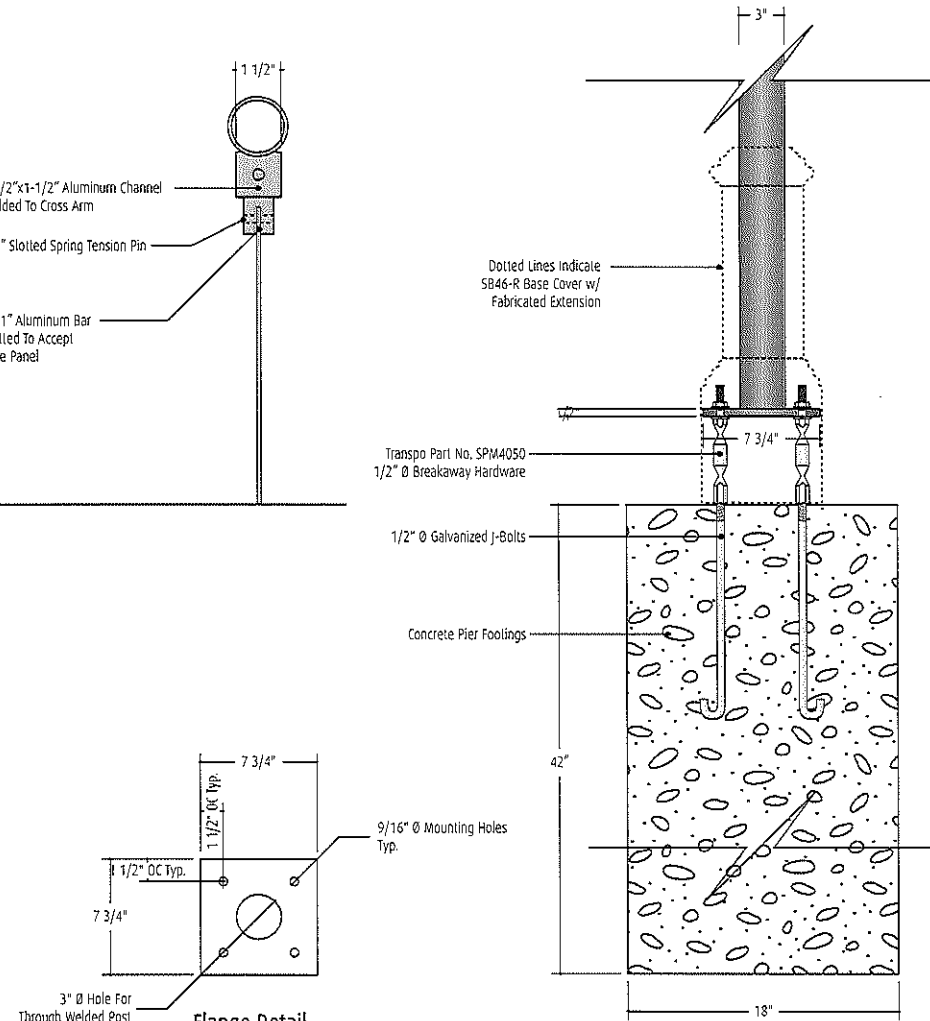

Footing Detail



1119 Wheaton
Troy, MI 48083
248.680.8970
www.asisignage.com

Project: Downtown Wayfinding
Location: Village of Clarkston
Date: March 24, 2023
Scale: 3/4" = 1' Drawn By: AD

205639

This drawing is the property of ASI. This drawing is submitted under a confidential relationship for a specified purpose and the recipient, by accepting this document, assumes custody and agrees that this document will not be copied or reproduced in whole or in part, nor its contents revealed in any manner or to any person except to meet the purpose for which it was delivered without express written permission from ASI.

DIR-1
General
Directional

CITY OF THE VILLAGE OF CLARKSTON

**RESOLUTION TO GO INTO CLOSED SESSION
TO DISCUSS SPECIFIC PENDING LITIGATION**

**SUSAN BISIO V CITY OF THE VILLAGE OF CLARKSTON CITY CLERK:
KAREN A. DELORGE**

At a City Council Meeting of the of the City of the Village of Clarkston, City Council, Oakland County, Michigan, held at the City Offices in the City of the Village of Clarkston, on Monday, April 10, 2023, at 7:00 p.m.

PRESENT: _____

ABSENT: _____

The following Resolution was offered by _____
with support from _____ moves to adopt the following
resolution:

WHEREAS, at the City Council Meeting held on April 10, 2023, the City Council desires to go into closed session to discuss specific pending litigation.

NOW, THEREFORE, BE IT RESOLVED that the City of the Village of Clarkston hereby agrees to meet in Closed Session, as permitted by State Statute MCL 15.268(e) on Monday, April 10, 2023 at __:__ p.m. during the City Council Meeting held on Monday, April 10, 2023 at 7:00 p.m., Michigan Time, at the City of the Village of Clarkston, 375 Depot Road, Clarkston, Michigan, 48346. The purpose of the Closed Session is to discuss the Susan Bisio v City of the Village of Clarkston City Clerk: Karen A. DeLorge, Oakland County Circuit Court Case Number 2023-199444-CZ, currently pending before Judge Martha D. Anderson, and to discuss the trial or settlement strategy in conjunction with the above-named lawsuit, which if this session were be held in an

open meeting would have a detrimental financial effect on the litigation or settlement position of the public body.

RESOLVED,

AYES: _____

NAYES: _____

ABSENT: _____

ABSTENTIONS: _____

RESOLUTION DECLARED ADOPTED.

Eric Haven, Mayor

CERTIFICATION

I, Karen A. DeLorge, being the duly appointed and qualified Clerk of the City of the Village of Clarkston, Oakland County, Michigan, do hereby certify and declare that the foregoing is a true and correct copy of a Resolution adopted by the City Council of the City of the Village of Clarkston at its City Council meeting held on April 10, 2023.

Karen A. DeLorge, City Clerk